



Low-Profile Floating Dock Assembly Instructions



Safety/Caution:

- * Always use caution while assembling the pier and while actively using the pier.
- * Wear protective gloves and appropriate safety glasses when assembling the product.
- * Be aware of pinch points between frames, around hinges and near piling sleeves.
- * Due to the nature of floating docks, the pier may shift or fluctuate in moving water, be mindful of footing while walking on the deck surface. All dock surfaces can be slippery when wet, use caution.
- * Please visit our FAQ section at www.patriotdocks.com for more information and details about floating docks.

Important Capacity Guidelines:

- * Manufacturer recommends at least two 48x24x12" floats per 8' dock frame. As a reference of buoyancy, a 200 lb. load over any single 48x24x12" float will submerge the float half way, a 400 lb. load will submerge the float completely. Consider adding more floats to increase buoyancy. A third float can be added to the middle portion of the frame (hole drilling required).
- * It is common for floating docks to be left in frozen water. Warranties do not apply to damage caused by ice. Each situation should be considered carefully before leaving the pier in frozen water.
- * Dock packages include the basic number of components to get started. Patriot's dock frame design allows for the flexibility to add length or change the configuration as desired. Additional parts may be required for certain configurations and applications.

General Locations for Floats, Pilings and Hinges

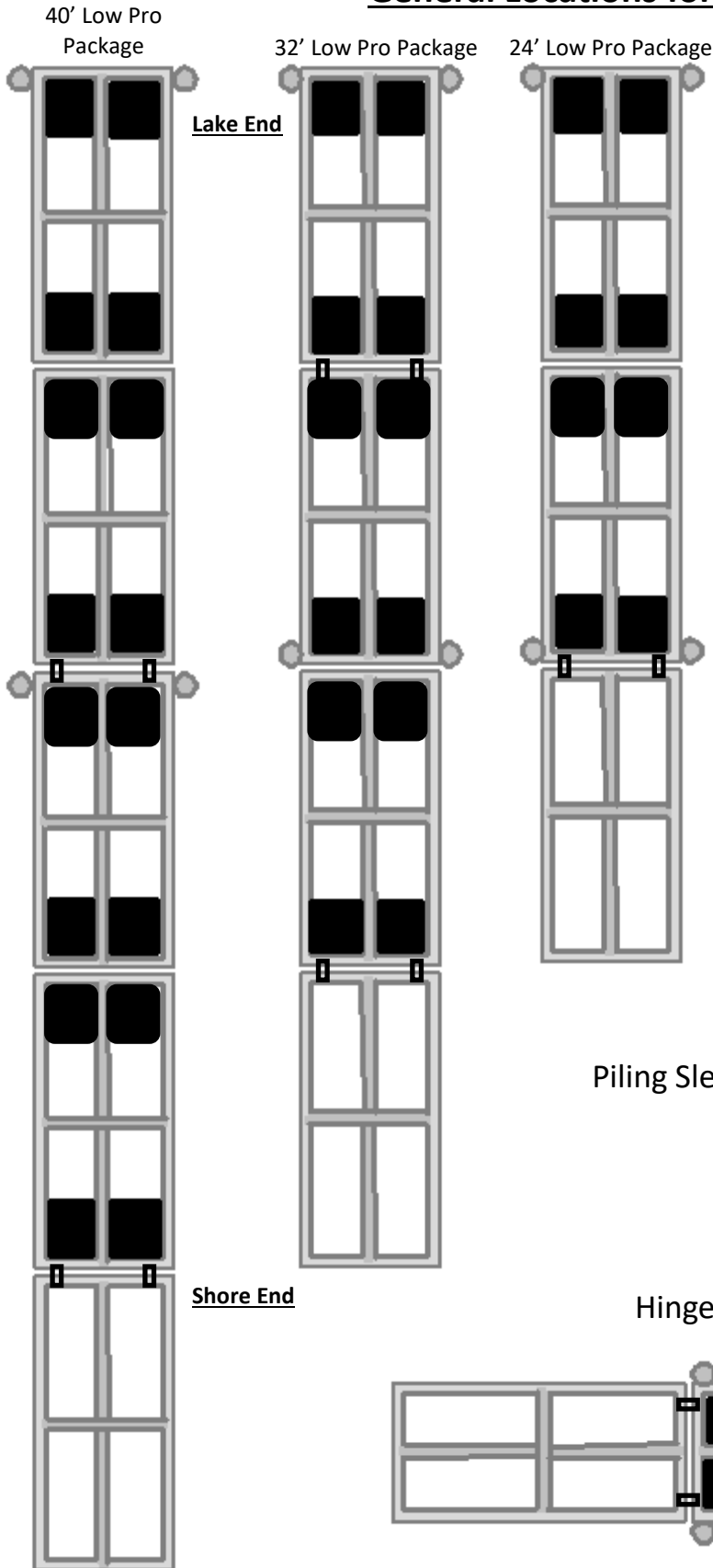

The minimum float requirement is two 48x24x12" foam filled rectangular dock floats per 8' Low-Profile dock frame. For additional buoyancy, consider adding more floats or increasing the size of the floats (hole drilling required).

Piling Sleeves are generally placed at the very lake end of the floating dock and near the shoreline. Additional Piling Sleeves can be used to increase stability and for anchoring additional sections. Pilings, Auger Bases and Pipe Caps are NOT included in the dock package as each floating dock situation requires unique anchoring. The Piling Sleeve is also used as the tie-off point for anchor leads, see **Anchoring Details** for more information.

Hinge Sets are typically used between 16' of framing and at finger locations. Generally, the first Hinge Set is placed between the first two frames, allowing the first frame to pivot and bridge from the dock to the shoreline, with the end of the ramp resting on the shoreline.

Side Ballast Floats are offered to increase the overall width of the floating dock to 5' and to act as bumpers for mooring boats.

Corner Brackets are available for reinforcing the low-pro frame. This bracket is designed for high stress areas of the dock.

See additional accessory details on last page.

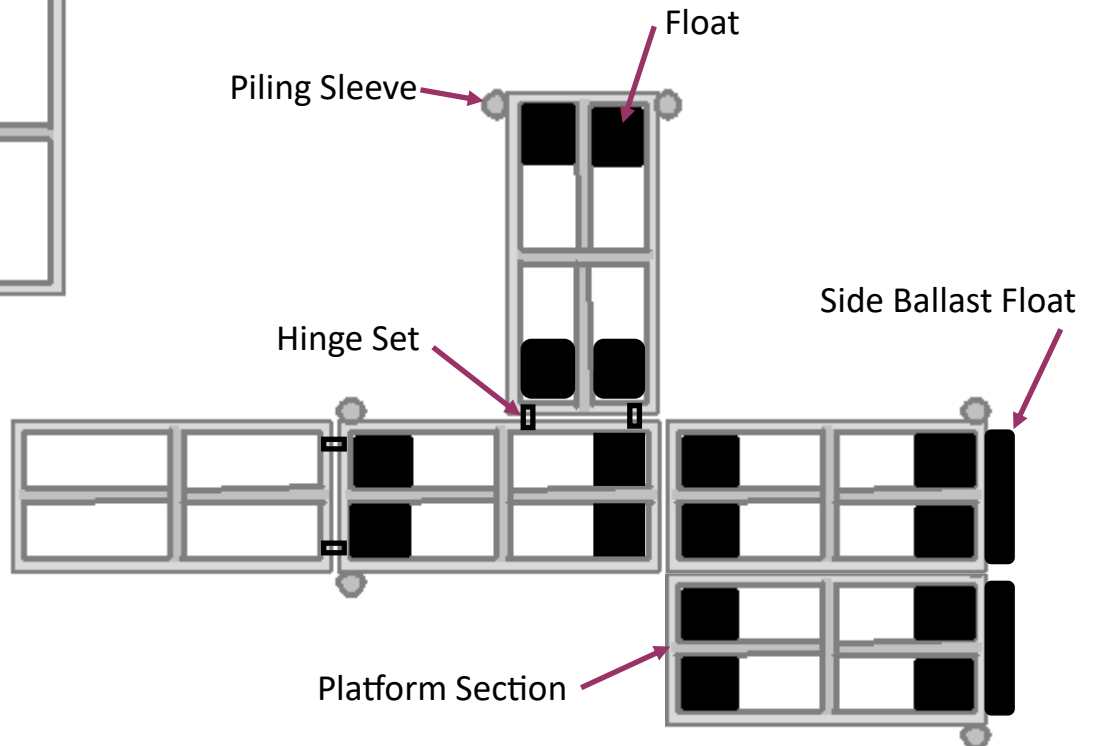

Step 1: Frame Assembly

4'x8' Low-Pro Frames can be joined end-to-end or side-by-side using four M10x100mm bolt/nut to create the desired configuration. Some of the assembly hardware used to join the frames may also fasten Float Brackets. **Fender washers must be used on both sides of the connection in locations where frames are being bolted together.** (anywhere the bolt head or nut would contact the frame without an additional material thickness like Float Bracket, Piling Sleeve or Hinge set).

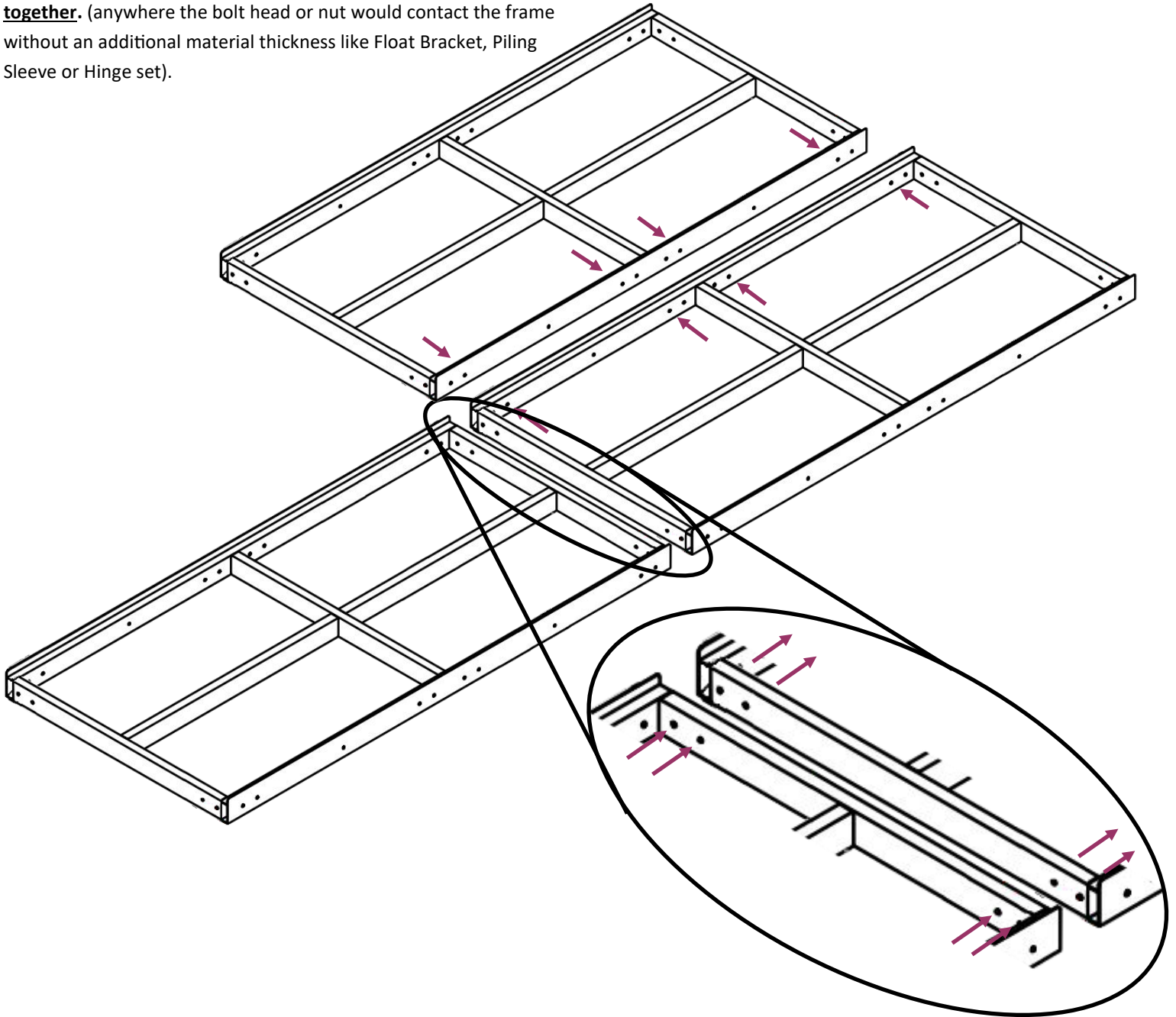

Step 2: Installing Hardware

Rectangular Floats are to be mounted on both ends of the 4'x8' Low-Pro Frame using four J-bolts with fender washers and nylock nuts. **The fender washer is used under the flange of the float.**

Hinges can be mounted to the 4' face of the Low-Profile frame, or, there are mounting locations on either end of the 8' face of the frame (used for adding fingers to the dock configuration). The hinge brackets should be installed with the welded round tube orientated upward. Hinge brackets are fastened using M10x60mm bolts with nylock nuts. After mounting the Hinge brackets, bring the two hinged faces together, aligning the 1" I.D. tubes while inserting the 3/4" I.D. x 4' Hinge Pipe. Install M6x30mm bolts and nuts to secure the Hinge Pipe in place.

Piling Sleeves are mounted at any of the frame's two-hole patterns using two M10x60mm bolt/nut.

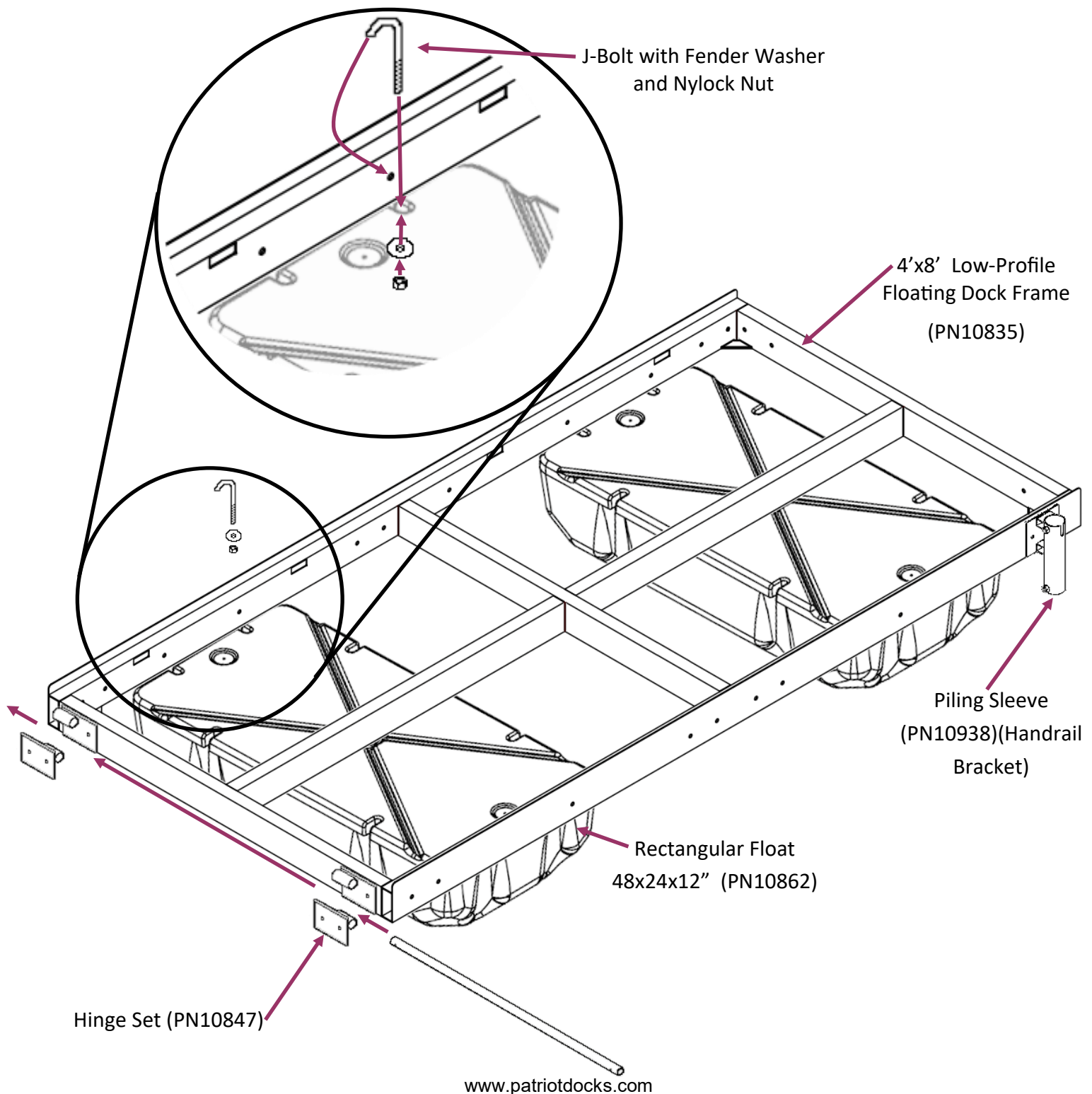

Anchoring Details and Recommendations

The manufacturer provides general guidelines to anchoring a floating dock. One should be aware of local regulatory restrictions. Due to the large degree of variation between floating dock applications and locations, carefully consider the details of your floating dock application when determining how to best anchor the pier. There are multiple ways to anchor a floating pier in place, each with its own pros and cons. Here we provide details and some general guidelines for each method.

Sleeve and Piling: This method of anchoring uses our available 1-1/2" Piling Sleeve to travel up and down on a 1-1/2" i.d. schedule 40 galvanized pipe. This is a ridged method of anchoring and is great for water depths up to 4' deep. This method requires little maintenance as the sleeves should move freely along the pipes with fluctuating water levels. Longer pipe is available for deeper applications but one should consider using the following chain and deadman weight method or a combination of both. Pipe can be driven into place on its own or through the Foot Plate Base for added stability. Auger bases are also commonly used to allow the pilings to be turned into the lake bottom. Pilings should be driven at least 12" into the lake bottom and deeper if a boat is to be moored to the floating pier.

Chain and Deadman Weights: This style of anchoring is a great all around method, especially useful in deeper water. The 1-1/2" Piling Sleeve is also used as the tie off point for the anchor chain. It is recommended that 5/16" galvanized chain and galvanized shackles be used as leads for the deadman weights. Chain leads should have a length twice that of the water depth. Floating docks will require between 500lbs—1500lbs of anchor weight depending on dock size and water conditions. Anchors should be placed at least every 32' of dock length and at key perimeter points as needed.

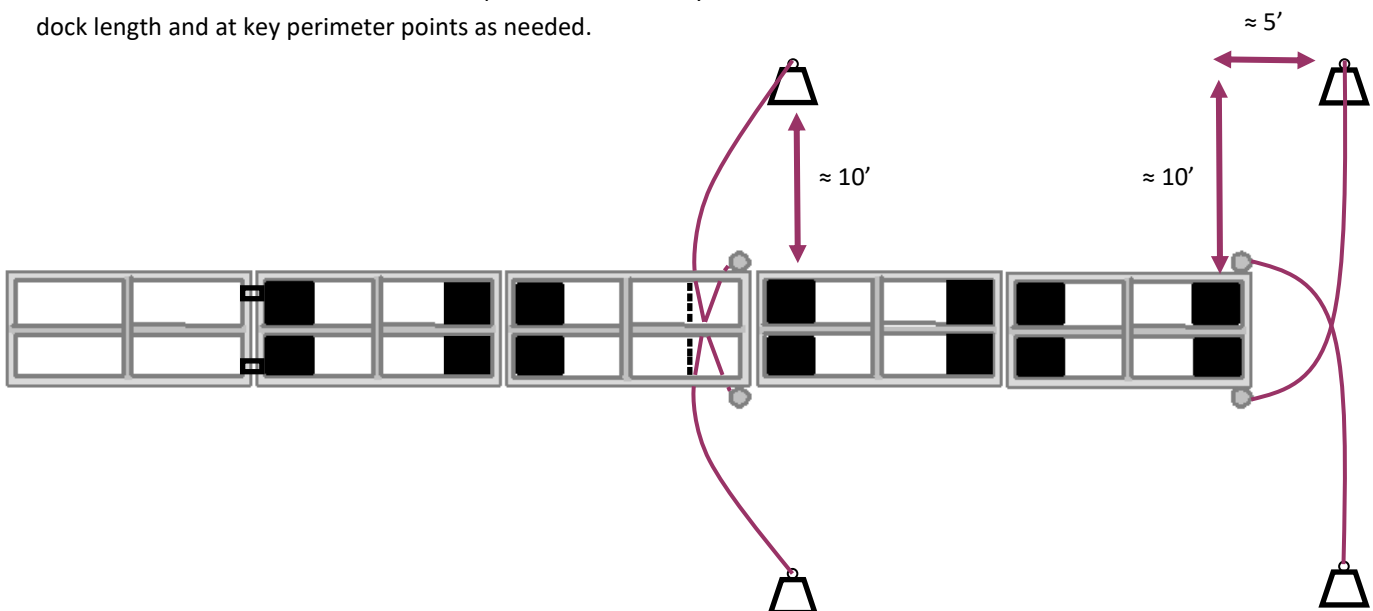
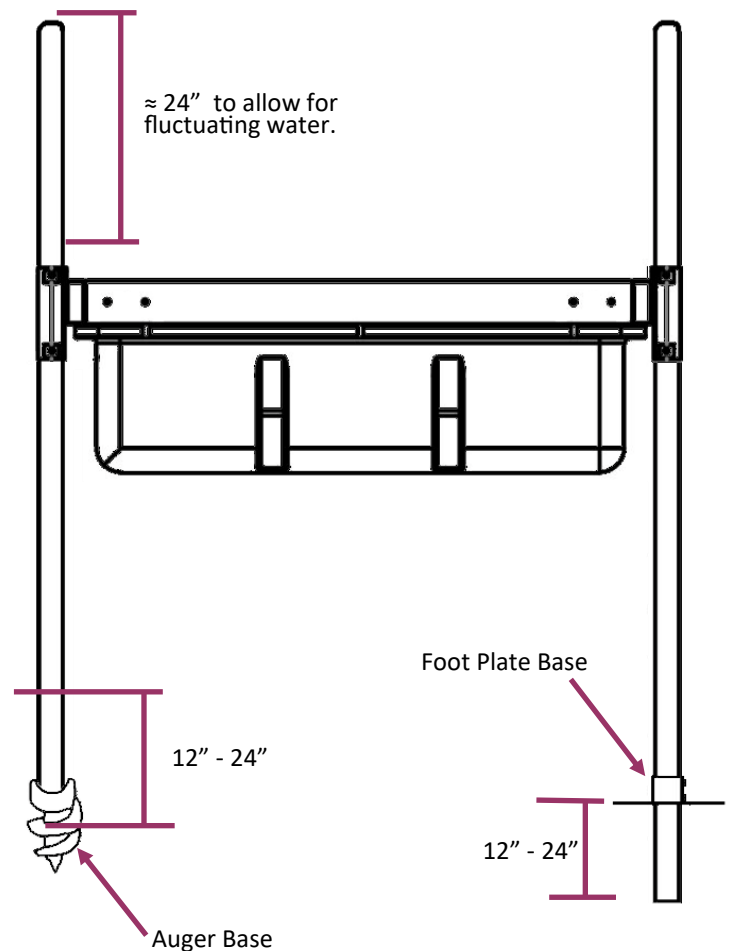

Optional Accessories include:

Handrail Assembly (PN10933 & PN10934) - Add handrails at desired locations for extra safety. Available in 4' and 8' lengths.

(#1) - Corner Bracket (PN10390) - The steel corner brackets are used in high stress areas of the pier. They bolt inside the corner of the low-pro frame to help resist twisting in the frame.

(#2) - Additional Floats (PN10862) - Add additional floats to increase buoyancy. Each float has a 390 lbs buoyancy rating. Floats mount to the Low-pro frame using the Float Mounting Bracket set (PN10849) A third float can be added to the low-pro frame (hole drilling required).

(#3) - Additional Piling Sleeves (PN10938) - Add more pilings to increase stability and to ensure firm anchoring.

(#4) - Piling Pipe (PN10813 & PN10814) - Use 1-1/2" I.D. Schedule 40 pipe as pilings in shallow water. Available in 6' and 8' lengths.

(#5) - Vinyl Pipe Caps (PN10823) - Used to cap the top of the piling pipe for a clean, finished look.

(#6) - Auger Base or Foot Plate Stanchion (PN10806 & PN10811) - Use the Auger Base or Foot Plate Stanchion on the end of the piling pipe to help stabilize the piling pipe. The piling pipe can be sleeved through the Foot Plate and be driven into the lake bottom.

(#7) - Side Ballast Float (PN10864) - Used to increase the overall floating dock width to 5' and adding 145lbs. of buoyancy each. Also acts as a bumper.

Wheels with mounting brackets (PN10821 Wheel, PN10874 /PN10423 Mounting bracket and axle) The wheels can be added to the pier to allow for rolling the dock in or out of the water. The wheels are attached to the dock frame using the Shore End Support bracket and Axle attachment

